

AutoCAD 2016 Preview Guide



Design every detail with Autodesk® AutoCAD® software, one of the world's leading CAD applications. Create stunning 2D and 3D designs with robust tools that can produce almost any shape imaginable. Share your work with confidence using TrustedDWG™ technology, the original and most accurate way to store and exchange design data. Speed detailing and documentation work with tools built to help increase efficiency and maximize productivity. Connect your workflow and collaborate with colleagues using integrated desktop, cloud, and mobile solutions. AutoCAD delivers the quality you can expect.

Table of Contents

- User interface..... 3**
 - File tabs 3**
 - Layouts 4**
 - Status bar..... 4**
 - Ribbon 5**
 - Help 5**
- Documentation 6**
 - Revision clouds 6**
 - Dimensioning 8**
 - Text..... 10**
 - Geometric Center object snap 11**
 - Isometric line grid 12**
 - Move/copy enhancement 12**
 - Property preview 12**
 - Command preview 13**
 - Selection highlighting color 13**
 - Xref enhancements 13**
 - PDF enhancements 14**
 - Plot dialog box 17**
- Design 18**
 - Section object 18**
 - Point clouds 19**
 - Render engine..... 24**
 - Coordination model 28**
 - BIM 360 add-in for AutoCAD enhancements 29**
- Installation and configuration 31**
 - Improved graphics 31**
 - System Variable Monitor..... 32**
 - Security..... 33**
 - Single service pack 35**

User interface

File tabs

The New Tab drawing file tab has been renamed to Start and remains persistent as you create and open additional drawings. The NEWTABMODE system variable has been renamed to STARTMODE. When set to 0 the Start tab is not displayed.

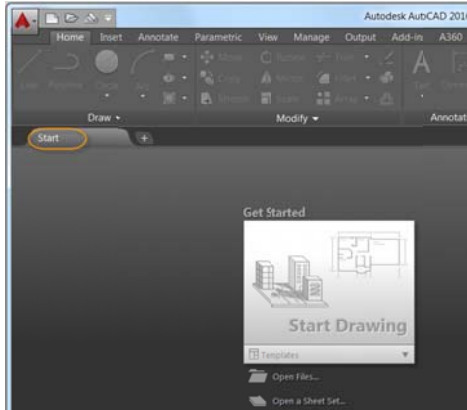

A new deployment option enables you to control whether the Start tab is displayed for install deployments.



You can press Ctrl+Home or use the new GOTOSTART command to switch focus from the current drawing to the Start tab. The new CLOSEALLOTTHER command offers command line access to close all the open drawings except the one in focus.

The Tip of the Day on the Learn page is updated every 24 hours. You can use the arrows to cycle through multiple tips one at a time and the tips can now contain inline images.



Layouts

Layouts now support drag and drop to move or copy layouts to positions that are hidden in the overflow menu. As you drag the selected layouts to the right or left edge of the layout tabs they automatically scroll, enabling you to drop the layouts into the proper position.



New controls in the right-click menu enable you to dock the layout tabs in line with the status bar or above it.

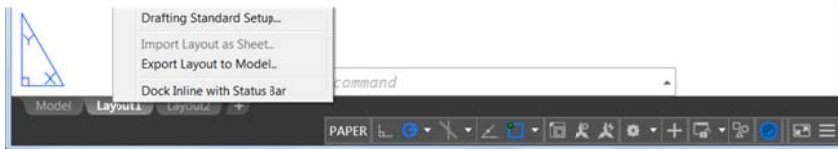
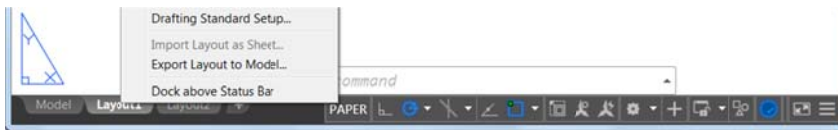

Status bar

The Status bar can now automatically wrap onto two rows when there are more icons than can fit into a single row. At any given time, the model tab and at least one layout tab are always displayed.

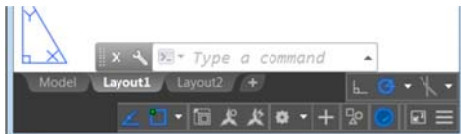

Isolate Objects and Lock UI have been added to the Status bar customization menu.



The Lock User Interface tool on the Status bar enables you to check and uncheck multiple UI elements at one time instead of having to reopen the flyout each time. Click the icon to enable or disable UI locking.

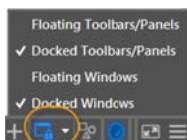

Ribbon

The new GALLERYVIEW system variable enables you to control whether Ribbon galleries are displayed. When GALLERYVIEW is set to 1, thumbnail preview images of blocks as well as dimensions, mleaders, and tables display in the Ribbon.

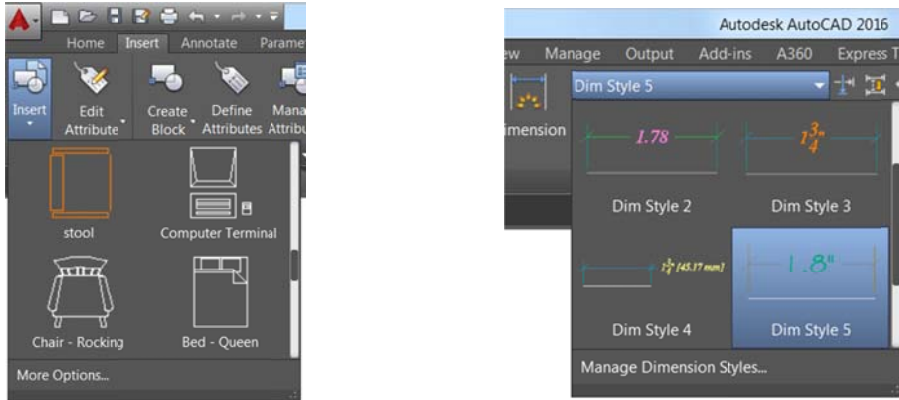

When it's set to 0, the Insert dialog box is displayed to access Blocks and traditional style lists are displayed in the Ribbon to access dimension, mleader, and table styles.

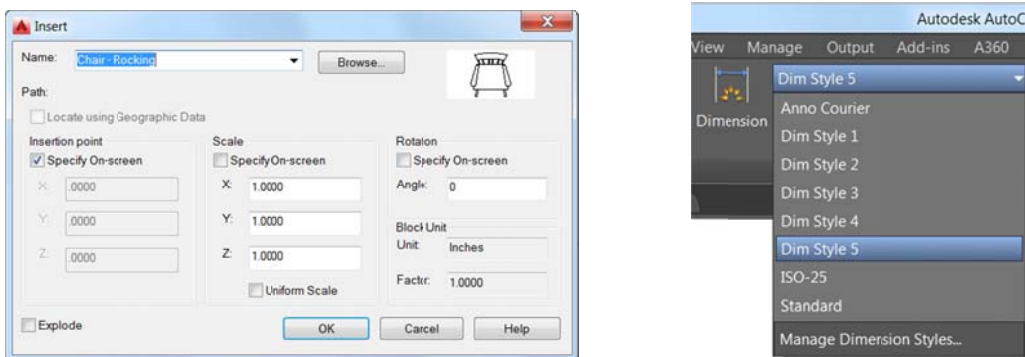

Help

Improvements to the AutoCAD Help system make it easier to access relevant Help content and tools.

Single sign-on

You are automatically signed into Help documentation when you sign into your A360 account from AutoCAD and vice-versa. Signing into Help documentation enables you to Like a Help topic.

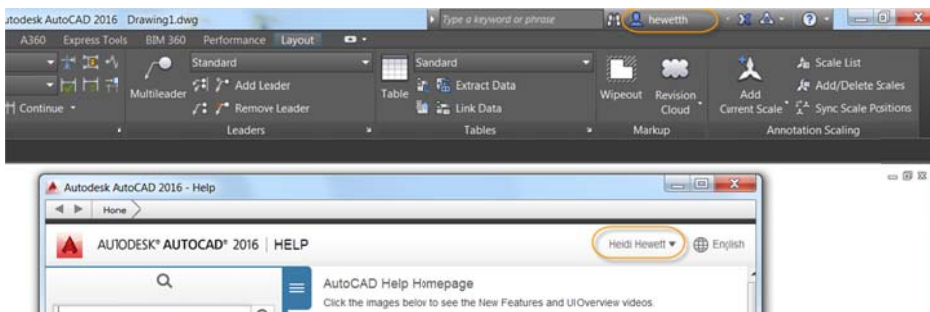

UI Finder

When you click on the Find link for a tool in the Help window, an animated arrow points to the location of that tool in the Quick access toolbar and Ribbon. In AutoCAD 2016 this functionality has been extended to include the Status bar and application menu.

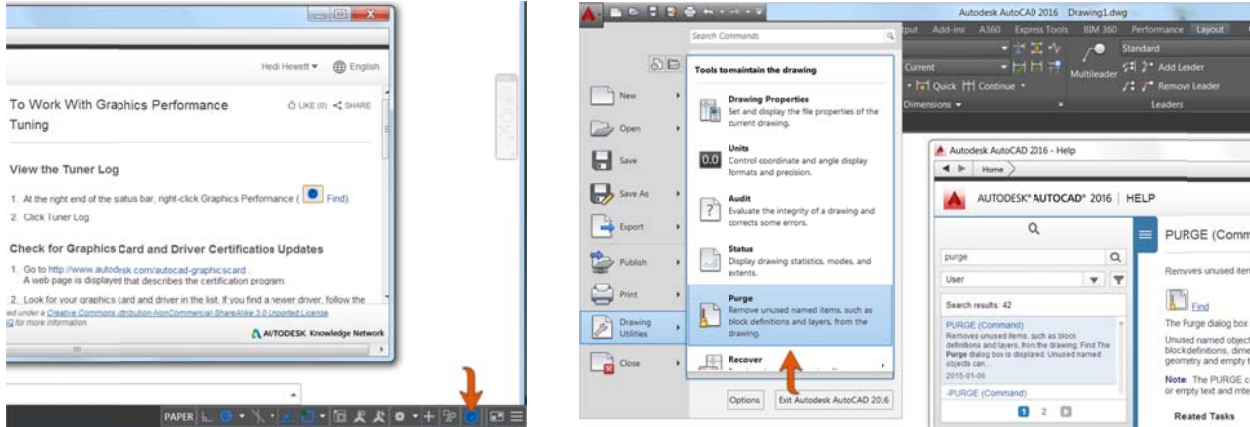

If an icon is available in the Status bar but not currently visible, the UI Finder will point to the Customization Status bar icon.

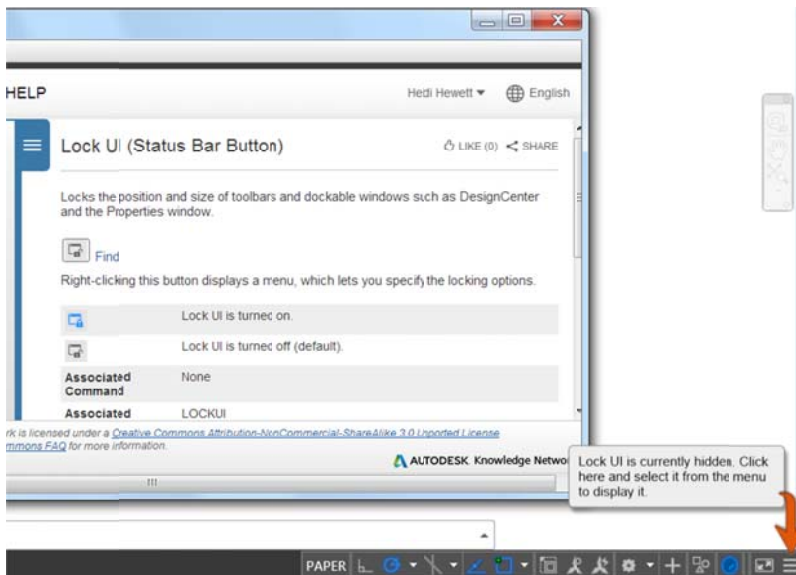

Documentation

Revision clouds

The Revision Cloud tool is enhanced in AutoCAD 2016 to provide more flexibility. It is accessible from the Annotate Ribbon panel and includes three methods of creation: rectangular, polygonal, and freehand—in addition to the Command line option to select an object. The last used creation method is remembered the next time the command is run. You can set your own default creation method using the REVCLLOUDCREATEMODE system variable.

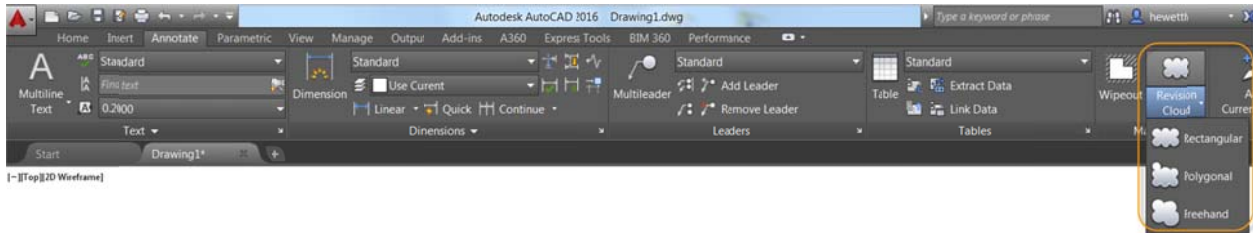

Whether you create rectangular, polygonal, freehand, or object revision clouds, editing their size and shape with grips is intuitive and easy. The number of grips displayed for revision clouds has been significantly reduced. The location and behavior of grips is based on the shape of the revision cloud. For example, if the revision cloud was generated by selecting a circle, it will include a center grip and four quadrant grips enabling you to edit it like a circle. If it was generated by picking polygonal points, it will include vertex and midpoint grips. If you prefer legacy display of grips, you can set REVLOUDGRIPS to Off.

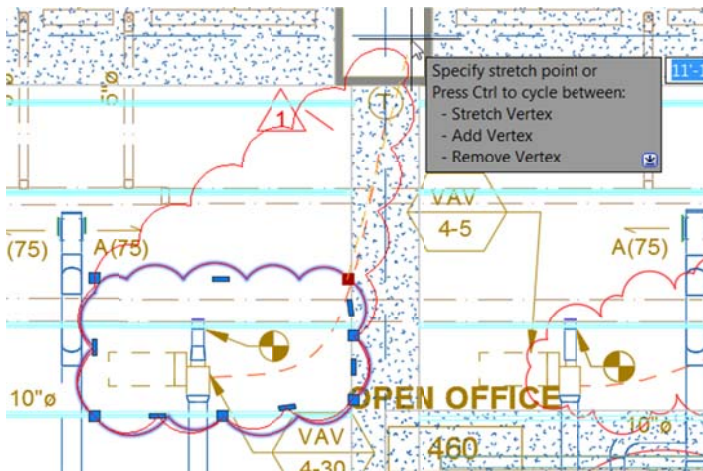

In addition to easier editing with grips, a new Modify option enables you to draw new revision cloud segments and erase selected portions of existing revision clouds. This was the #4 AUGI wishlist request!

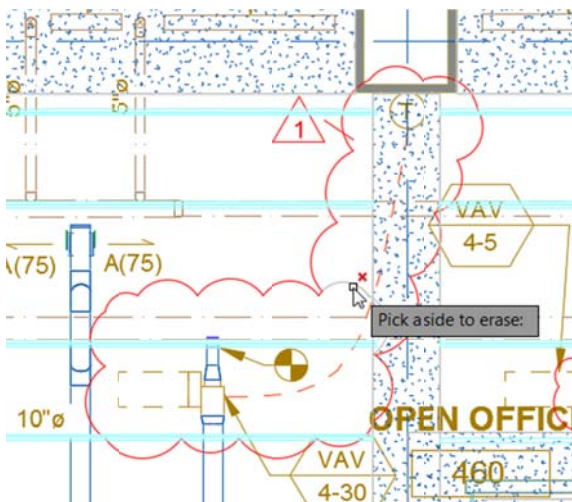

Dimensioning

DIM command enhancements

The DIM command is significantly enhanced in AutoCAD 2016 and is now accessible from the Annotate ribbon tab. Next to it you'll find a new dimension layer control. Dimensions created using the DIM command are automatically placed on the specified layer. If an appropriate dimension layer doesn't currently exist in the drawing, you can quickly create one and apply it to the DIM command using the new DIMLAYER system variable.

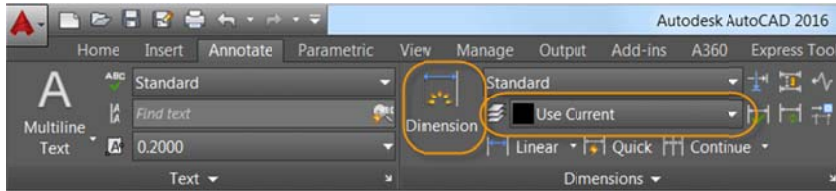

Options within the DIM command are now displayed at the command line and in the right-click menu, eliminating the need for you to remember which options are available and how to enter them.

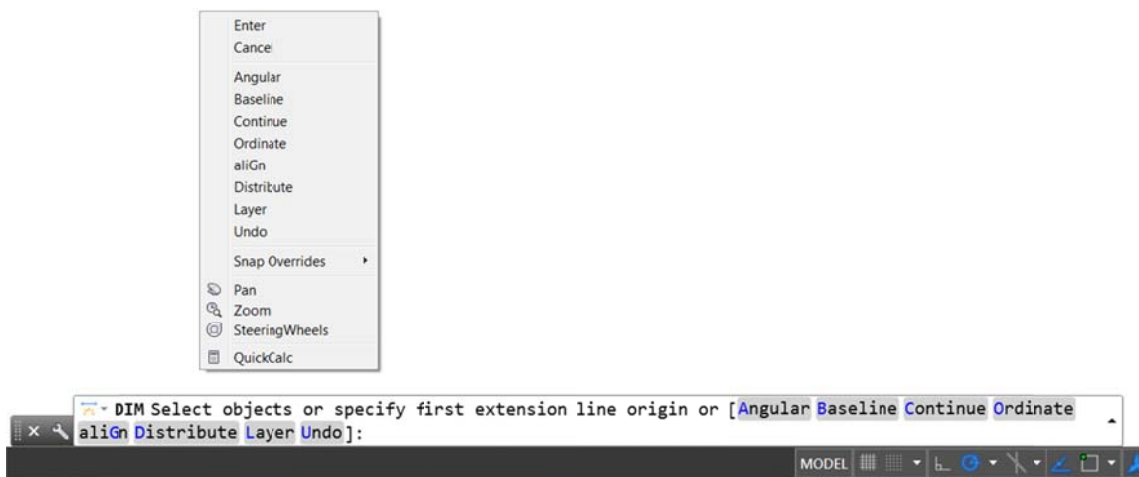

However, even the need to specify Dimension options is significantly reduced in AutoCAD 2016. Now the DIM command automatically creates appropriate dimensions based on the type of objects you select. A preview as you pass the cursor over those objects enables you to see the resulting dimension before you actually create it. For example if you launch the DIM command and hover the cursor over a linear object, a preview of the appropriate horizontal, vertical, or aligned dimension is displayed. After selecting the object you can either place the dimension or hover the cursor over another non-parallel linear object to display and place an angular dimension.



If you hover the cursor over a circle or an arc object, a preview of a diametric or radial dimension is displayed and the command prompt offers relevant options including the ability to switch between Radius and Diameter. Arc objects include the additional option to create an angular dimension.

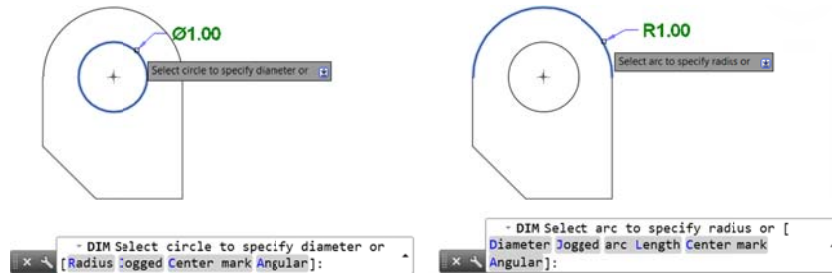

The DIM command further simplifies creating dimensions by eliminating prompts to modify the dimension text and angle. Instead, the default values are automatically applied. Mtext, Text, and Text Angle options are available from the command line and right-click menu if you choose to change the default values.

If you attempt to create a dimension that overlaps with other similar dimensions, a cursor menu offers options to automatically move, break up, or replace the existing dimension in addition to simply placing the new dimension on top of the existing ones without affecting them.

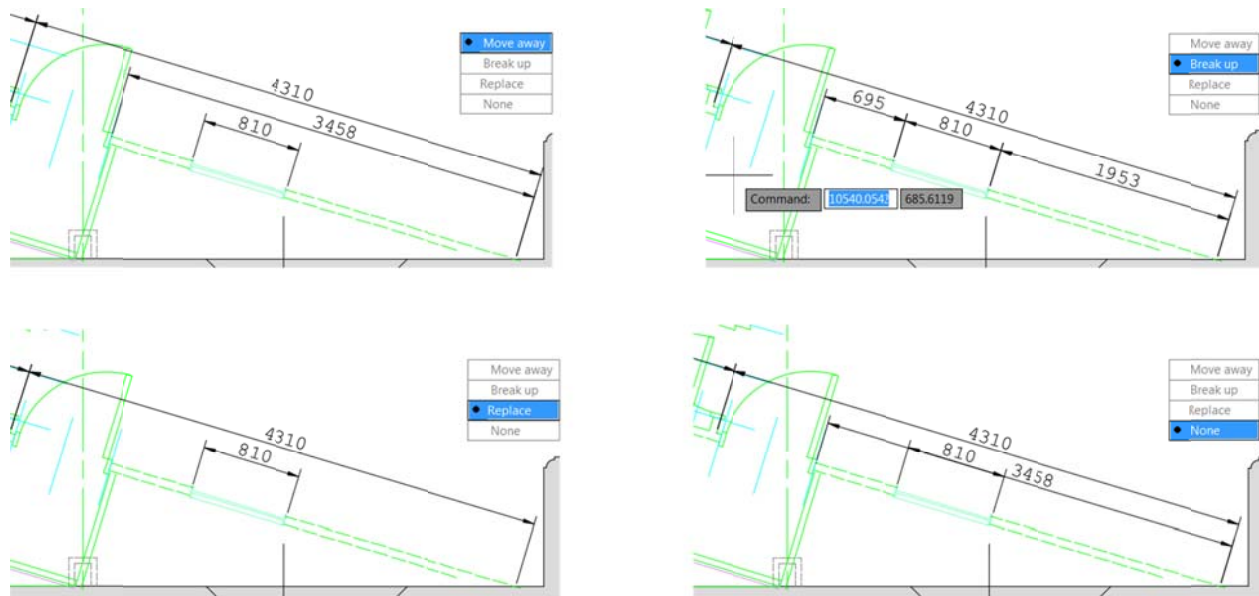

When using the Baseline or Continue options, you are automatically prompted to select the first extension line origin.

Regardless of which type of dimension you create, the DIM command remains active, enabling you to easily place additional dimensions until you exit the command.

Text wrap in Dimensions

When editing dimension text, a width sizing control is displayed above the text, enabling you to specify the width for text wrapping. This was the #8 AUGI wishlist request.

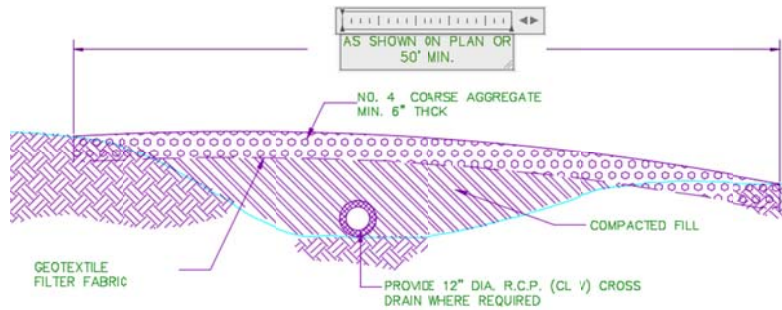

Text

To address the AUGI #5 wishlist request, a new Text frame property has been added to Mtext objects, enabling you to create a border around the text.

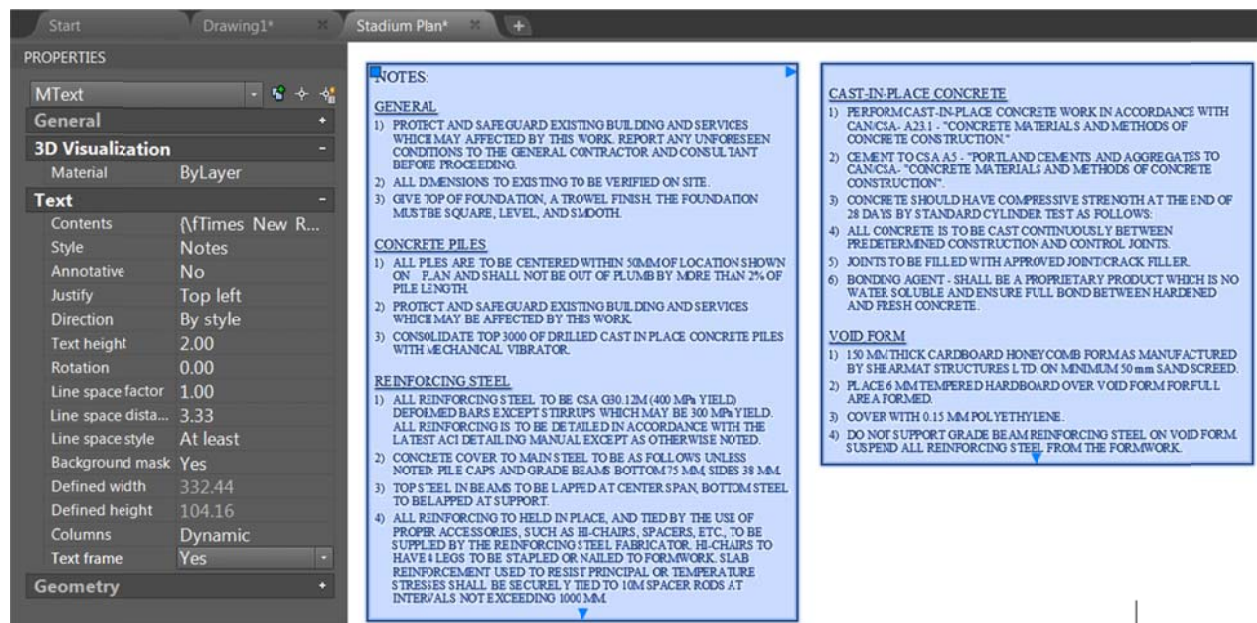

The Match text formatting button in AutoCAD 2016 is "sticky," so you can apply the properties of the selected text multiple times within an Mtext object. It's available for all objects that use Mtext including mleaders, tables, and dimensions.

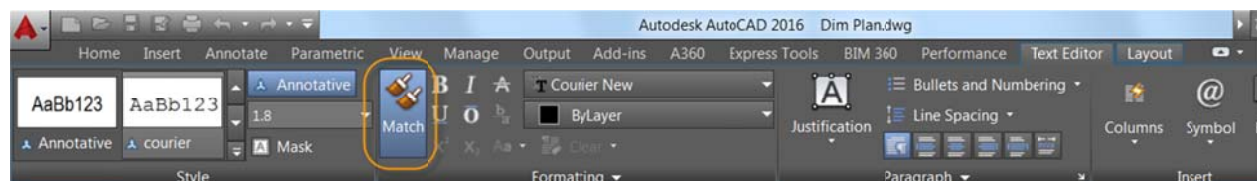

Geometric Center object snap

The #2 AUGI wishlist request has been granted with the addition of a new Geometric Center object snap. Using the Geometric Center object snap you can snap to the geometric center of polygons and closed polylines. It is accessible by entering GCE at the command line as well as from typical osnap controls, including the Drafting Settings dialog box, Status bar, and contextual menus.

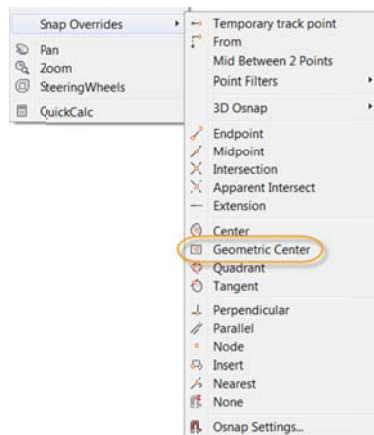
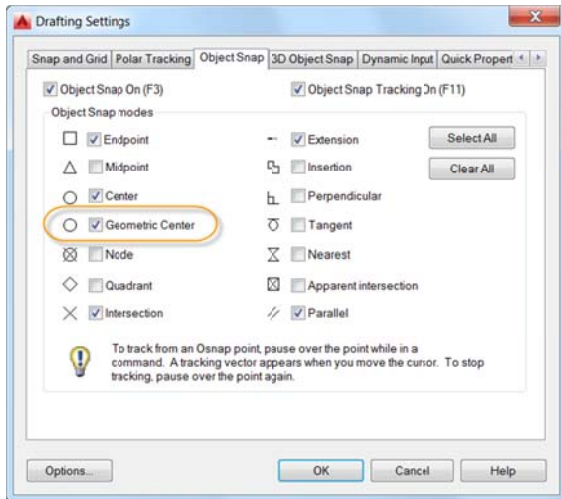

Tooltips distinguish the Geometric Center osnap from the traditional Center osnap.

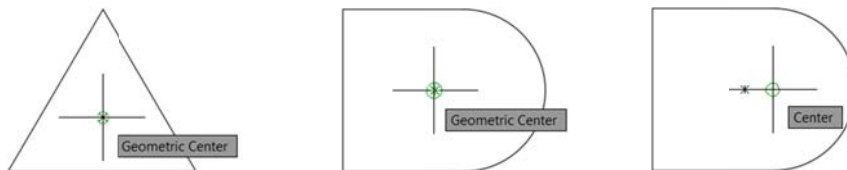

A new object tracking glyph distinguishes the Center object snap from other object snaps that display the traditional "+" glyph.

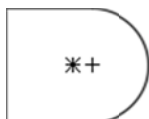

Isometric line grid

The isometric line grid now updates when you change the isoplane via the Isometric Drafting Status bar control, as well as with the F5 toggle.

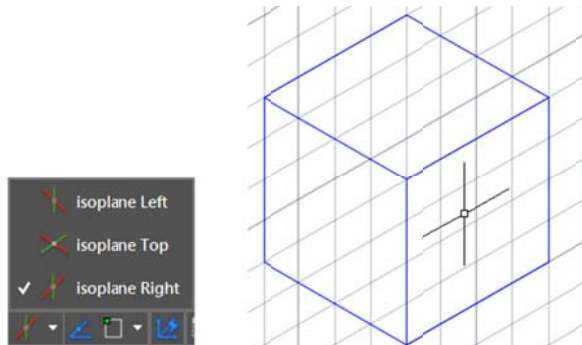

Move/copy enhancement

When you move or copy a large number of objects together in the 2D Wireframe visual style in AutoCAD 2016, move function preview is generated quickly, enabling you to move the selected objects freely without significant lag.

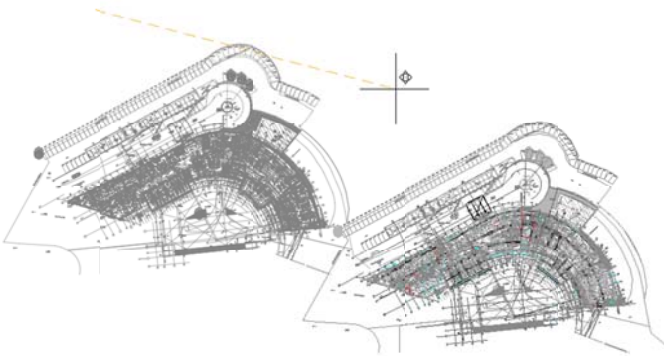

Property preview

Property preview performance has been improved in AutoCAD 2016. For example, when you want to preview color changes for a large selection set, you can move your cursor freely on the properties palette or Ribbon controls to preview the change.

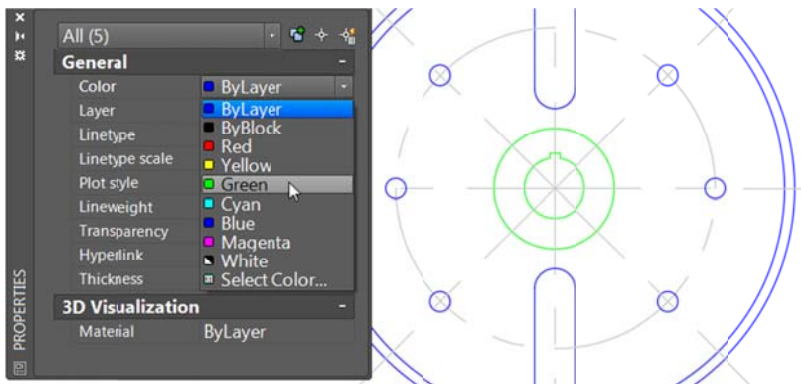

Command preview

Command preview functionality has been extended in AutoCAD 2016 to the BLEND, ERASE, STRETCH, ROTATE, and SCALE commands, helping you predict the results and minimizing the need to undo the operation.

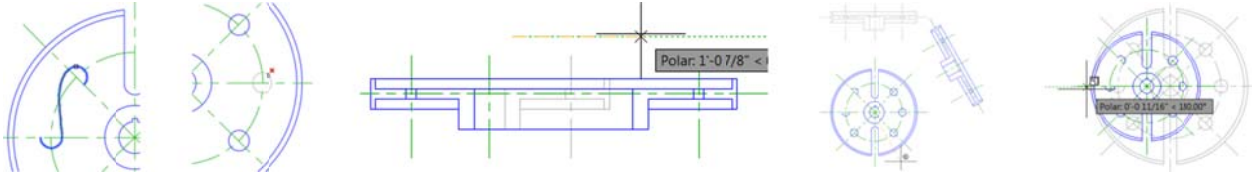

Selection highlighting color

With hardware acceleration turned on in AutoCAD 2016, the selection effect color can be customized by clicking on the Selection Effect Color drop-down list on the Selection tab of the Options dialog box.

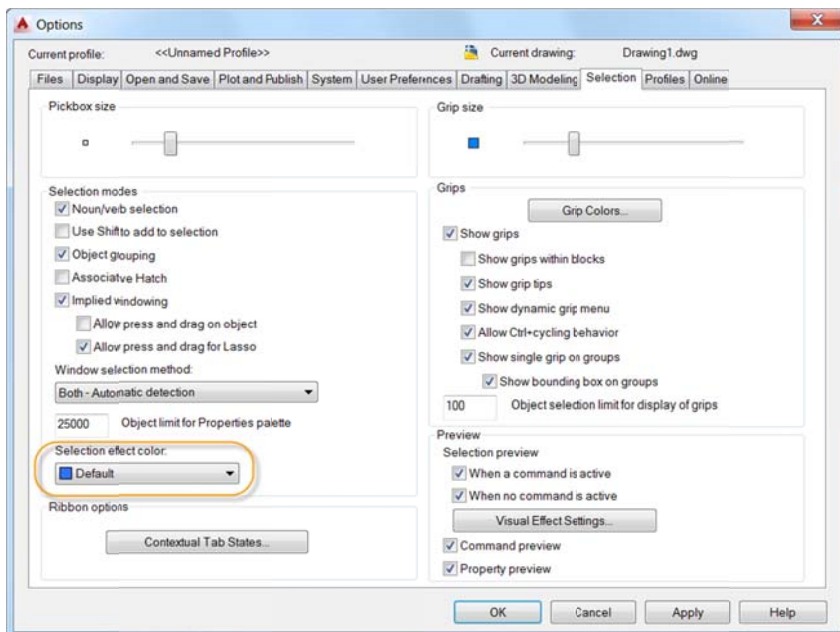

Xref enhancements

In AutoCAD 2016 you can now control the display of layers for objects in xref drawings that were not set to “ByLayer,” for layer property updates in the host drawing. A new system variable, XREFOVERRIDE, enables you to control the display of the xref layers: set XREFOVERRIDE=1, and the xref objects will behave as if their properties were set to “ByLayer.”

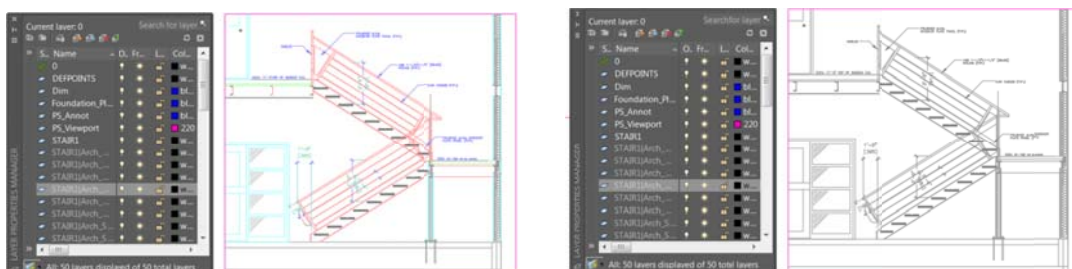

To help distinguish layers in xref drawings from layers in host drawings—and because xref layers cannot be selected in the Properties palette—xref layers are no longer displayed in the Properties palette. Xref layers are still displayed in the Ribbon layers list but are now shown in gray text.

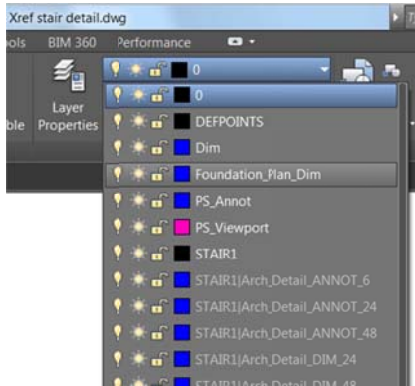

PDF enhancements

PDF support has been significantly enhanced in AutoCAD 2016, offering improved performance, flexibility, and quality. Zooming and panning a drawing with PDF underlays, even large ones, is considerably faster in AutoCAD 2016.

TrueType fonts in Mtext and Text with any formatting options, as well as Polygonized text (TTF font plotted as Geometry), SHX text, and Unicode characters, are now searchable in PDF output files. And PDF plotting performance for drawings that contain a large amount of text, polylines, and fill patterns is improved.

The Export to DWF/PDF Options dialog box has been split into two separate dialog boxes; one for DWF and one for PDF. Both are accessible from the Output Ribbon tab.

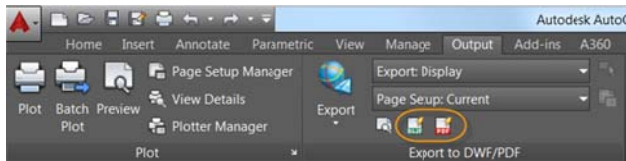

PDF Options now include the PDF quality and font handling controls as well as new controls for hyperlinks and bookmarks.

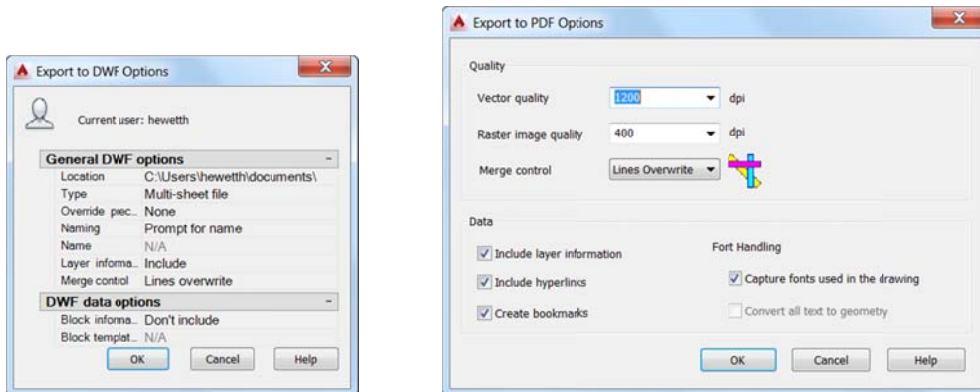

The hyperlinks control enables you to include hyperlinks from the drawing in the PDF file. For example, these may include links to sheets, named views, external websites, and files. It also supports links from different types of objects such as text, images, blocks, geometry, attributes, and fields. The bookmarks control exports sheets and named views as bookmarks so that you can easily navigate between them when viewing the PDF file.

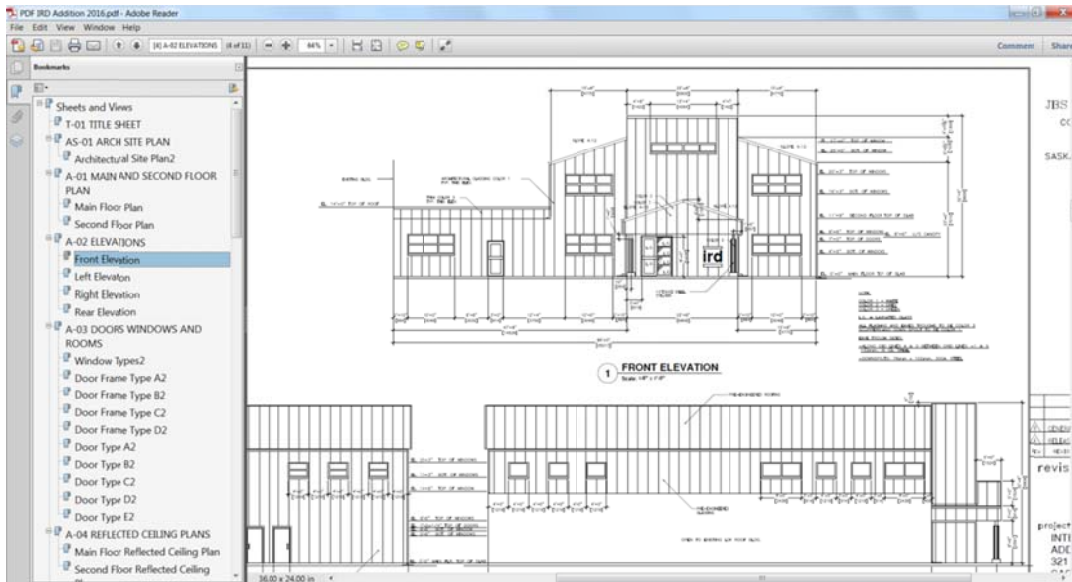

When using the Plot tool to create PDF files, you can now choose from four predefined PDF presets, offering a quick way to apply different PDF output options that meet various needs. If you select any PDF pc3 from the Printer/plotter drop-down list, a PDF Options button is displayed, providing convenient access to the PDF Options dialog box.

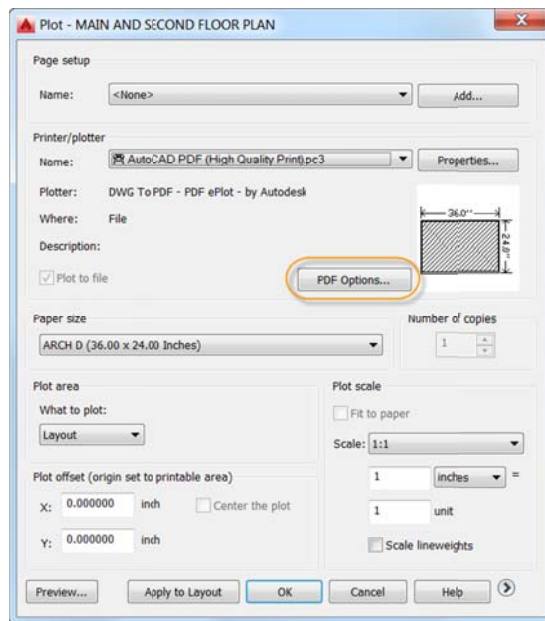
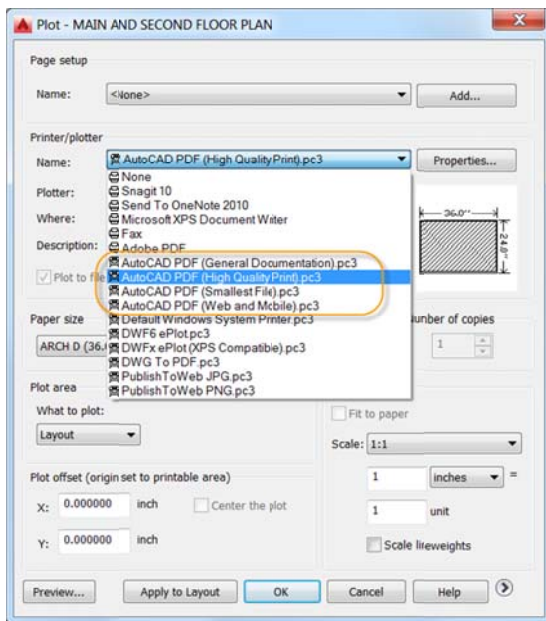

Similar PDF presets and options controls are available when creating PDF files using the Export to PDF and Batch Plot tools.

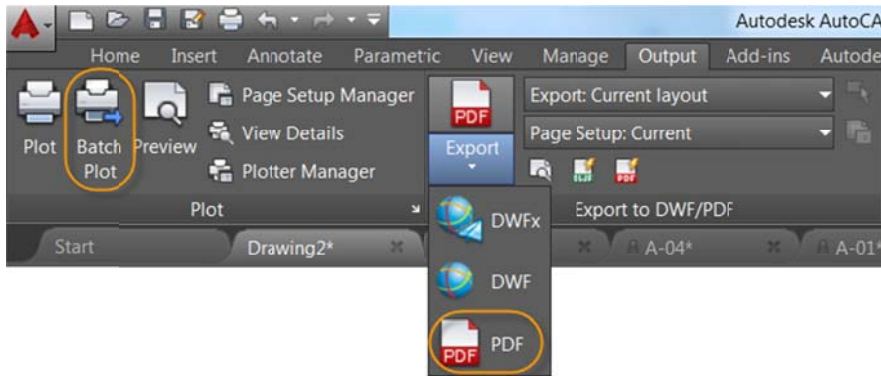

The Sheet Set Manager has also been updated to support these PDF enhancements.

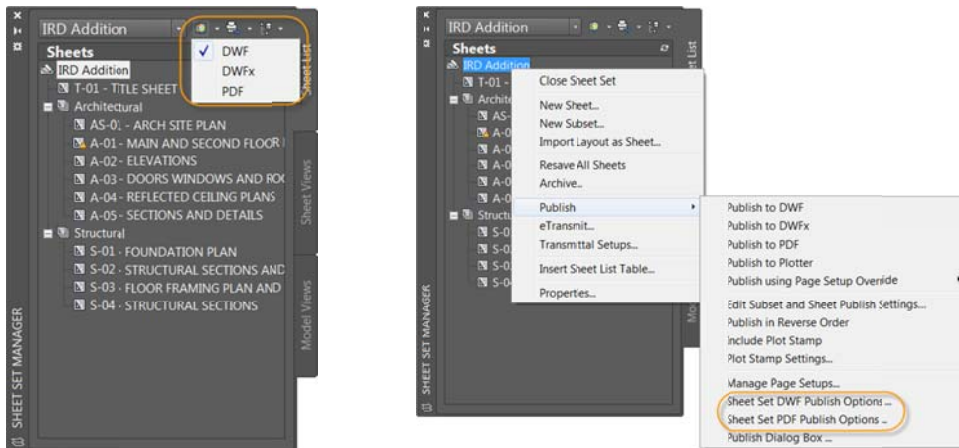

Regardless of which of these methods you use to create PDF files from AutoCAD, viewing them in a PDF viewer offers additional advantages, including enhanced support for Unicode characters.

Layout names are automatically displayed as page labels in the PDF file, making it easy to identify sheets when viewing the PDF.

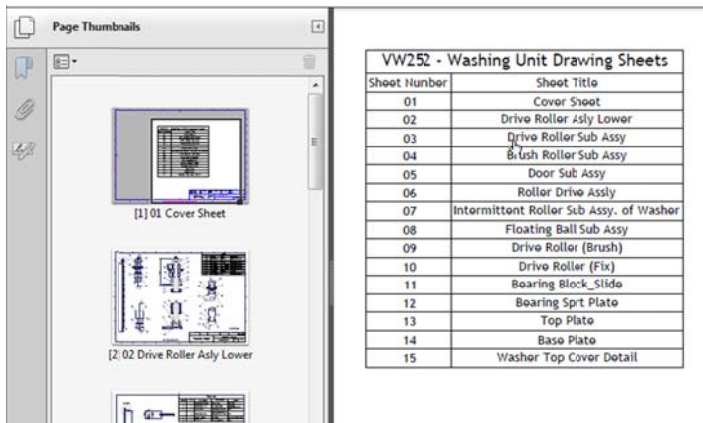

Text that was created as SHX in the AutoCAD drawing can be highlighted, copied, and even searched in the Comment List.

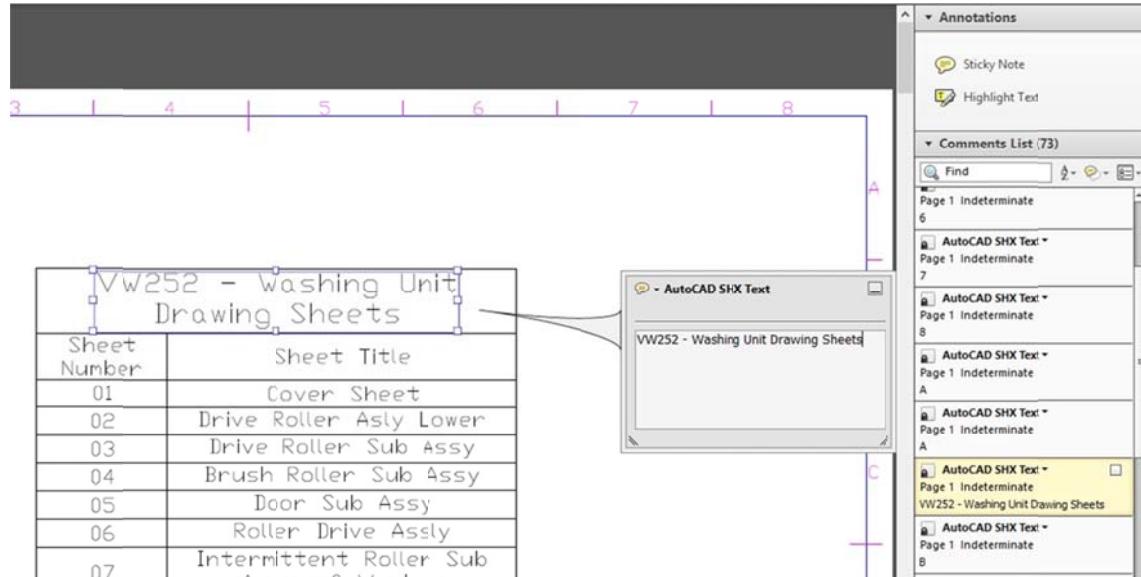

Plot dialog box

The default display for the Plot dialog box in AutoCAD 2016 is expanded, giving you immediate access to all the plot controls. You can collapse or expand the dialog box using the control in the lower-right corner.

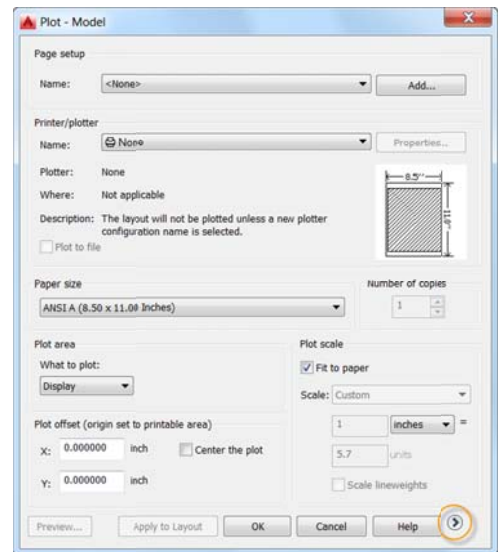
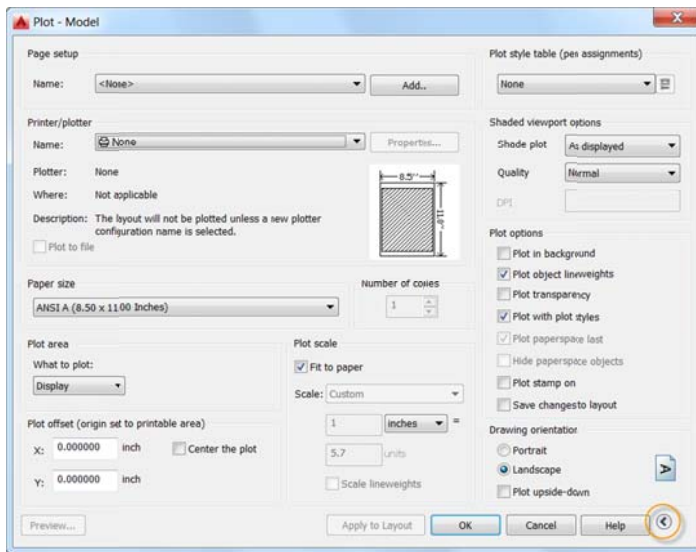

Design

Section object

Section objects, created using the Section Plane tool, provide more flexibility in AutoCAD 2016. The Section Plane tool creates a section object that acts as a cutting plane through 3D objects, including solids, surfaces, meshes, regions, and now point clouds.

The section object's type can be set to represent a simple cutting plane, a bounded area, or volumetric area. In AutoCAD 2016, a new Slice type has been added to the section object.

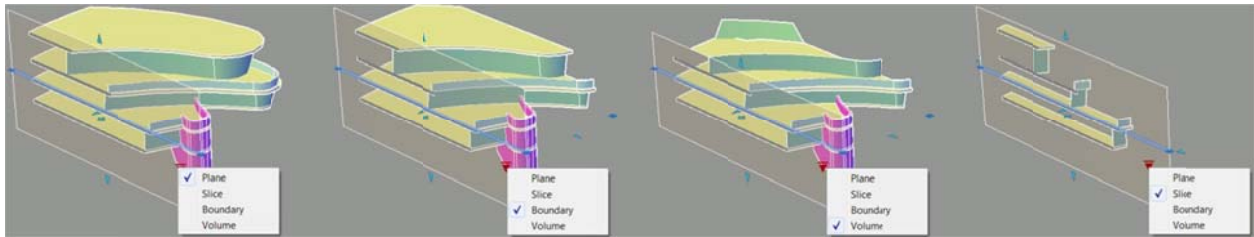

The Slice type generates a thin cut through the model that always contains parallel front and back section planes. The Slice type has a slice thickness property and cannot contain jogs. When switching to a slice type, any jogs in the section object are removed.



Some grips have been offset or repositioned to make them easier to select and now operate more consistently regardless of the view or whether polar tracking is toggled on or off. For example, the flip grip is now displayed on the side of the plane opposite the visible model instead of on the same side as the visible portion of the model.

The contextual panel for the section object has been changed to a contextual tab and has more controls. It has tools for toggling Live Sectioning on and off, changing the section type, adding jogs, and rotating the object in 90-degree increments. The tab also has edit boxes with spinner controls for adjusting the offset of the section plane and the thickness of the slice. This is useful for changing these values when grips are not accessible from different views. There are also tools for generating section blocks for solids and for extracting section lines from point clouds.

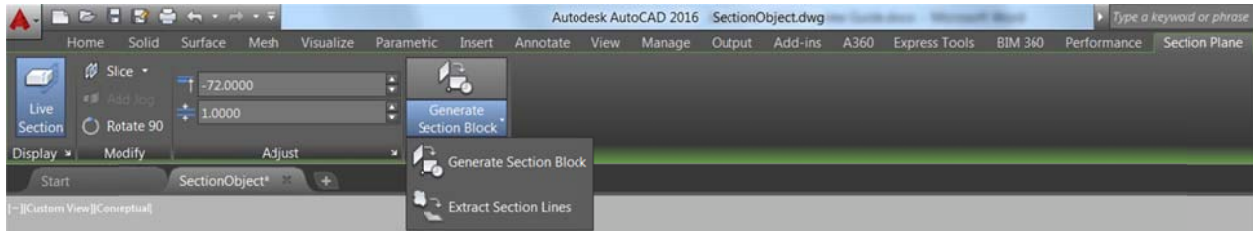

Point clouds

AutoCAD 2016 offers significant enhancements to make working with point clouds easier and more efficient.

Section planes

Point clouds now support section planes. A new Section Plane drop-down list has been added to the Point Cloud contextual Ribbon tab. It enables you to create section objects for the selected point cloud, either for different orthogonal orientations or by specifying points. When you create a section object, its initial size and position is based on the extents of the visible 3D objects in the drawing.

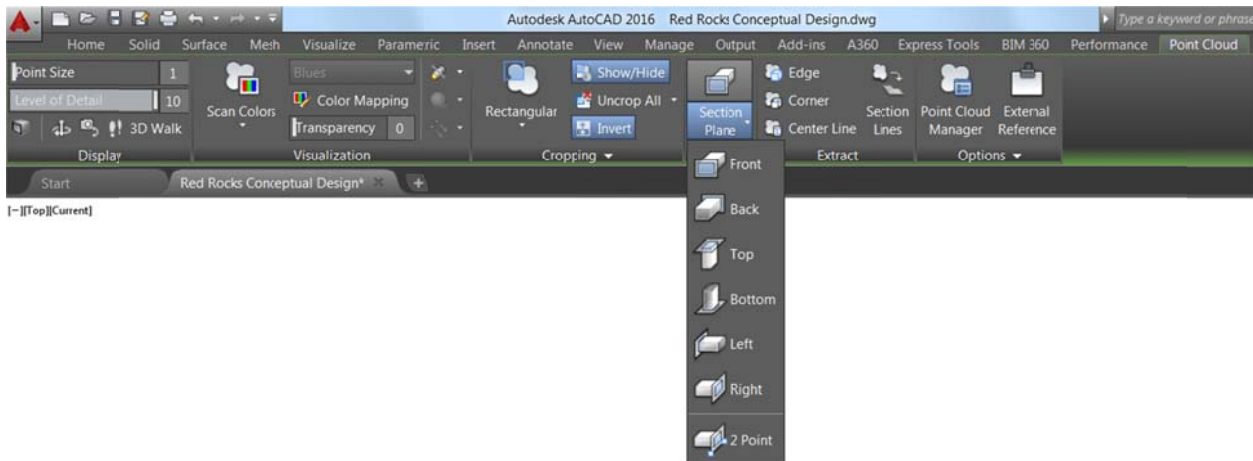

Extract Section Lines

The new Extract Section Lines tool enables you to generate section lines from a point cloud when Live Sectioning is turned on. It can be accessed from the section object's contextual Ribbon tab or right-click menu as well as from the point cloud contextual Ribbon tab. After selecting the point cloud from which to extract section lines, a dialog box enables you to adjust the section line extraction settings. Use the Preview result control to see the result and make desired changes before creating the section lines.

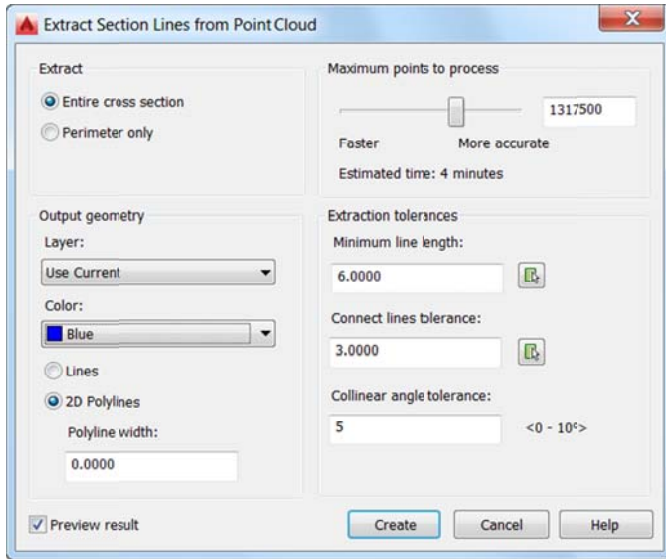

After pressing Create, a progress meter displays on the Status bar while processing the points. The time to process depends on the number of points analyzed.

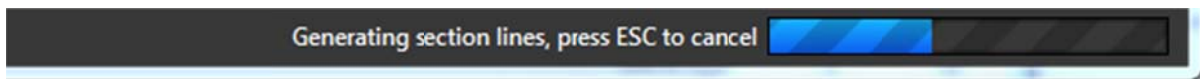

When processing is finished, the section geometry is created.

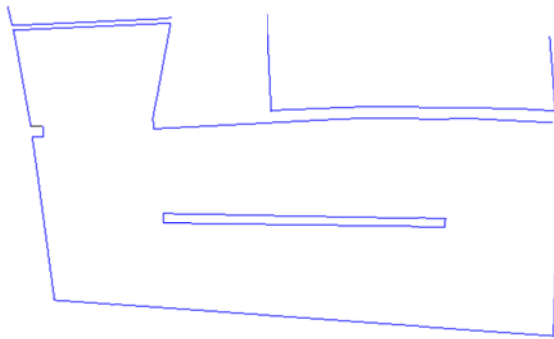

Transparency control for point clouds

It can sometimes be difficult to see geometry created when snapping to or tracing over point clouds since the points can partially obscure the geometry. To help address this problem, point clouds now support transparency. You can set transparency in the properties palette and from the Point Cloud Ribbon tab when a point cloud is selected.

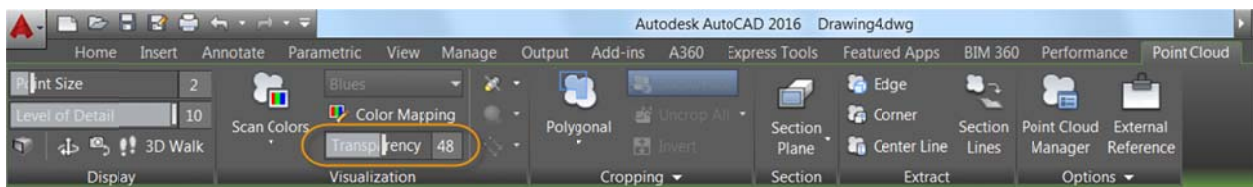

The images below show the point cloud before and after transparency has been applied.



Dynamic UCS

Point clouds now support Dynamic UCS. If an attached point cloud file includes segmentation data as indicated in the Properties palette, you can begin drawing on the face of a point cloud without having to manually change the UCS. Simply ensure Dynamic UCS is turned on and all point cloud object snaps are turned off. Then pass the cursor over a face of the point cloud to begin drawing.

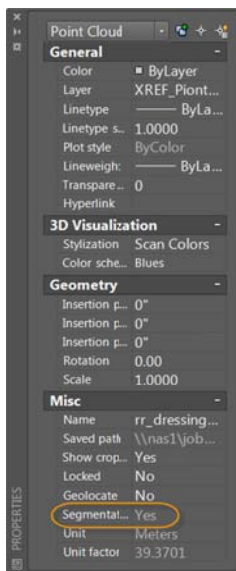

Point cloud object snaps

The 3D Object Snap tab in the Drafting Settings dialog box has been rearranged to make room for additional point cloud object snap modes, including Intersection, Edge, Corner, Perpendicular to Edge, and Centerline.

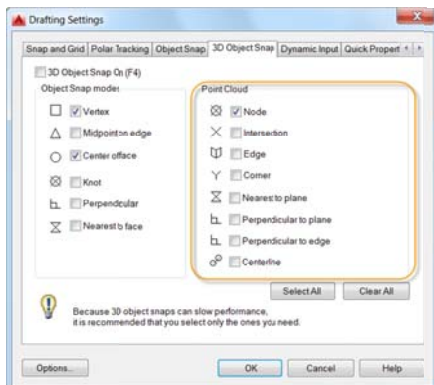

The Intersection point cloud object snap enables you to snap to the apparent intersection of two lines of a sectioned point cloud.

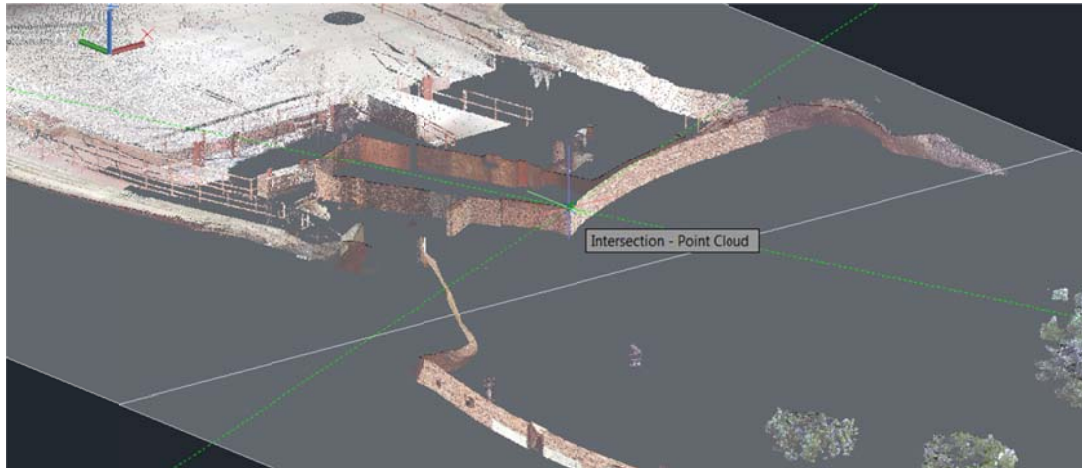

The Edge object snap snaps to the edge of two intersecting planes and the Corner object snap snaps to the corner of three intersecting planes.

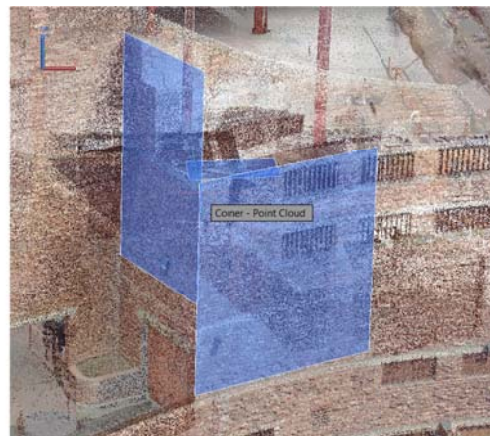
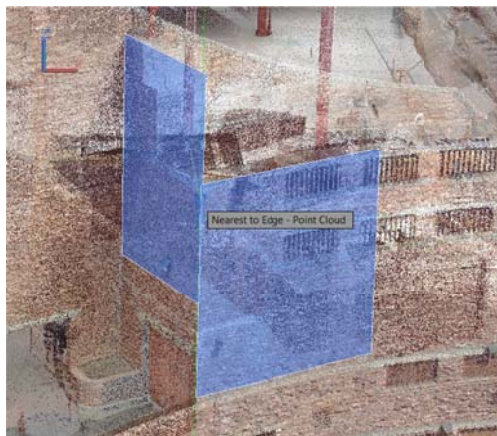

The Perpendicular to Edge object snap enables you to draw perpendicular to the edge of two intersecting planes.



The Centerline object snap enables you to snap to the centerline of a cylindrical shape.

Point cloud crop states

The Cropping panel on the Point Cloud Ribbon tab includes new tools that enable you to save and restore named cropping states. The cropping states maintain the cropping boundary of the point cloud as well as the visibility of the scans and regions as they're displayed in the point cloud manager. You can use the new POINTCLOUDCROPSTATE command to list and delete crop states.

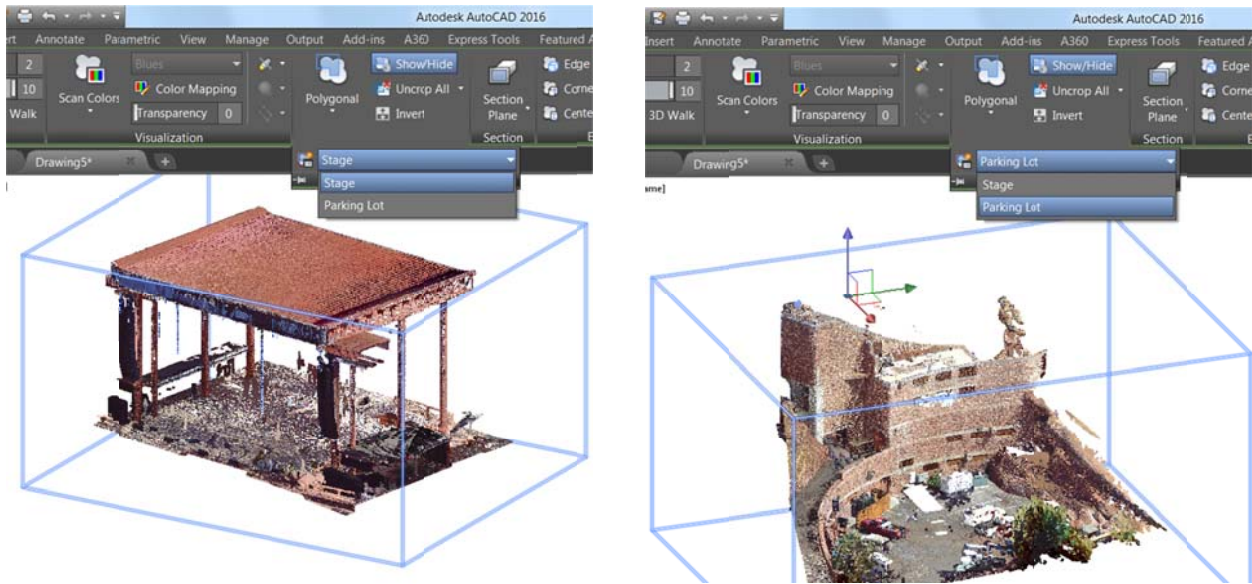

Point Cloud Manager

The Point Cloud Manager now always displays the on/off buttons for scans and regions. Names are truncated if necessary to display the button, since a tooltip always displays the full name when the cursor is moved over an item.

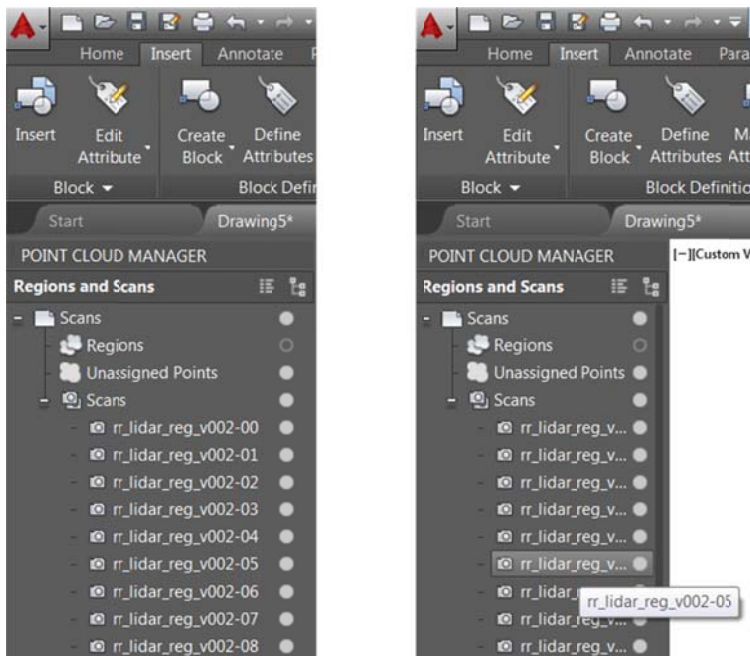

Render engine

A new rendering engine in AutoCAD 2016 replaces the previous rendering engine. This physically based path tracing renderer provides a simpler way to render in AutoCAD that can produce better results. The new render UI has significantly fewer settings compared with the previous render UI. Many of the previous settings were removed as they are no longer valid with the new rendering engine.

The Render Ribbon panel on the Visualize Ribbon tab is updated to support the new rendering engine. It includes a size drop-down list where you can quickly select from standard predefined render sizes or choose More Output Settings to access the new Render to Output Settings dialog box.

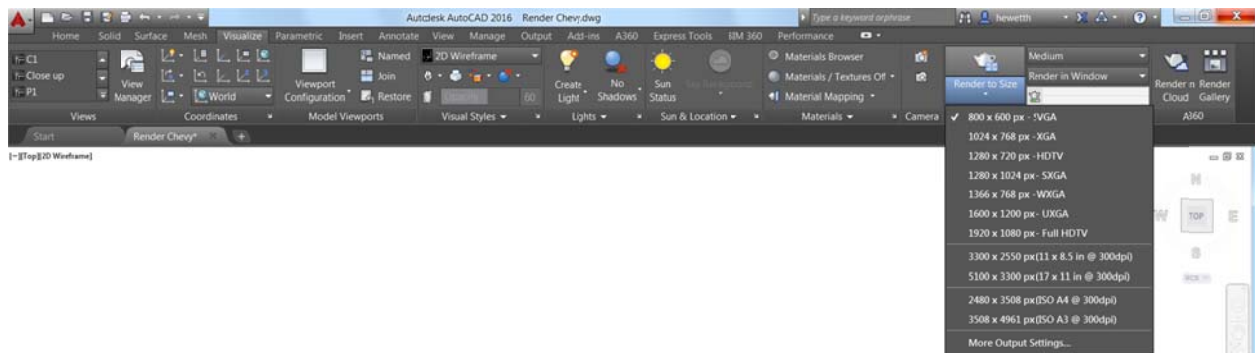

In the Render to Size Output Settings dialog box, you can specify the image size and resolution. And you can choose to automatically save the rendered image to a file, including BMP, TGA, TIF, JPEG, and PNG formats.

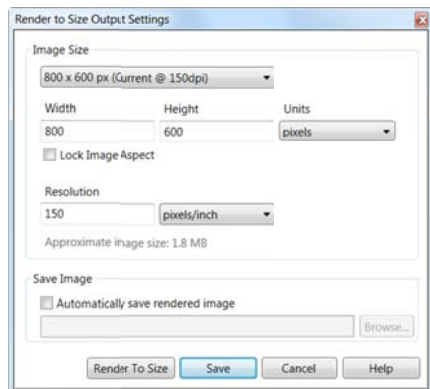

The Render Presets list on the Visualize Ribbon tab includes additional options, enabling you to control the render quality by setting either the number of levels to render or how much time to render. Tooltips assist you in making an appropriate choice.

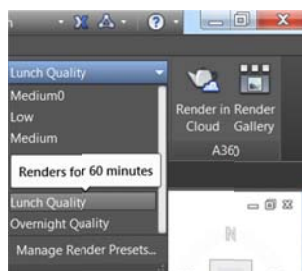
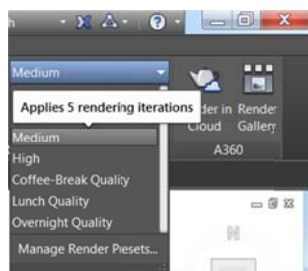

The new Render Presets Manager is much simpler than the previous Render Presets Manager. You can create, modify, and delete custom render presets. Specify render preset name and description as well as the duration and accuracy. You can render directly from the Render Presets Manager, choosing to render in the Render window, the current viewport, or a specified region in the current viewport. When rendering in the render window, a drop-down list enables you to specify the render size in addition to selecting one of the preset render quality options.

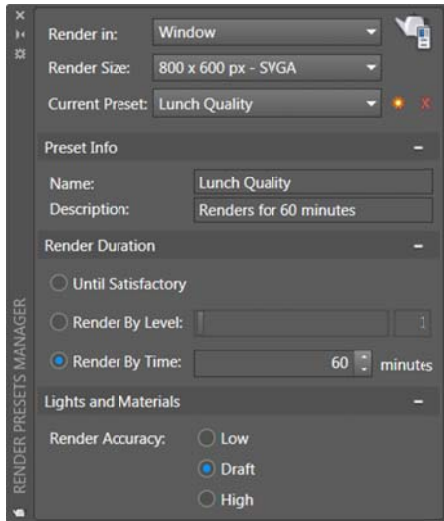

A new Render Environment and Exposure palette offers powerful new image-based lighting (IBL) environments. You can access it from the Render panel of the Visualize Ribbon tab.

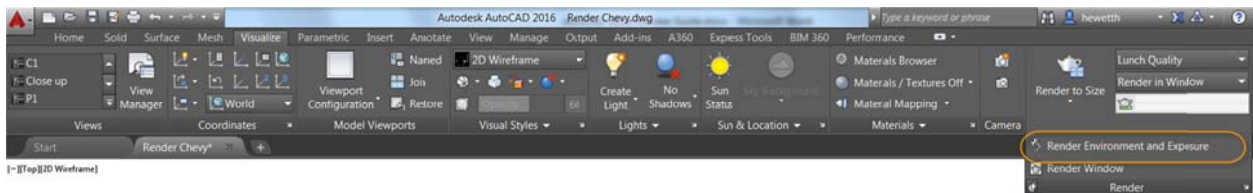

When the Environment control is turned on, you can select from predefined IBL environments.

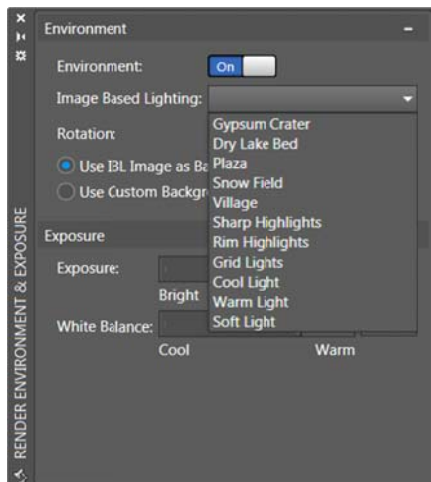

The IBL environments automatically apply lighting effects. Some of them include 360-degree background images that emulate a realistic environment as you orbit around the model. The viewport must be in a perspective view and you must render to see the IBL environment.



A control in the Render Environment and Exposure palette enables you to use a custom background image. Custom images are static and do not emulate a realistic 3D environment as you rotate.



Additional controls in the Render Environment and Exposure palette enable you to adjust the Exposure and White Balance.

The Exposure slides between Bright and Dark.

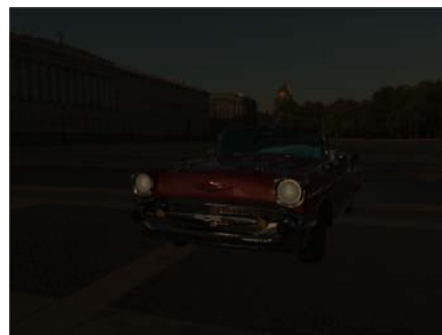

The White Balance slides between Cool and Warm.



The new render window displays the current render process and enables you to save a snapshot, zoom in and out while rendering, and print the rendered image. Render history is displayed in the expanded section of the render window.

Preview	Output File Name	Output Size	Output Resolution	View	Render Time	Render Preset	Render Statistics
	C:\Users\hewetth\Documents\0 Autodesk\AutoCAD\Preview Guide\Images\Render12.png	800 x 600 px 5.33 x 4 in	150 pixels/inch	C1	00:00:01	Medium	Date 12/16/2014 11:04:12 AM Geometry Count 65436 Light Count 7 Material Count 7
	Render Chevy-Temp0006	800 x 600 px 5.33 x 4 in	150 pixels/inch	Current	00:00:01	Medium	Date 12/16/2014 11:03:30 AM Geometry Count 65436 Light Count 7 Material Count 7
	Render Chevy-Temp0005	800 x 600 px 5.33 x 4 in	150 pixels/inch	Current	00:00:01	Medium	Date 12/16/2014 11:03:19 AM Geometry Count 65436 Light Count 7 Material Count 7
	Render Chevy-Temp0004	800 x 600 px 5.33 x 4 in	150 pixels/inch	Current	00:00:02	Medium	Date 12/16/2014 11:03:02 AM Geometry Count 65436 Light Count 7 Material Count 7
	Render Chevy-Temp0003	800 x 600 px 5.33 x 4 in	150 pixels/inch	Current	00:00:02	Medium	Date 12/16/2014 11:02:33 AM Geometry Count 65436

Coordination model

AutoCAD 2016 has added support for attaching coordination models to a drawing. A coordination model is a model used for virtual coordination of various trades through the pre-construction and construction phases of a project. Coordination models are not displayed in the 2D Wireframe visual style.

Navisworks support

AutoCAD 2016 supports attaching Autodesk® Navisworks® files, in either the NWD or NWC file format. You can attach them using the same tools you use to attach other reference files, including the Attach tool and the External References Manager.

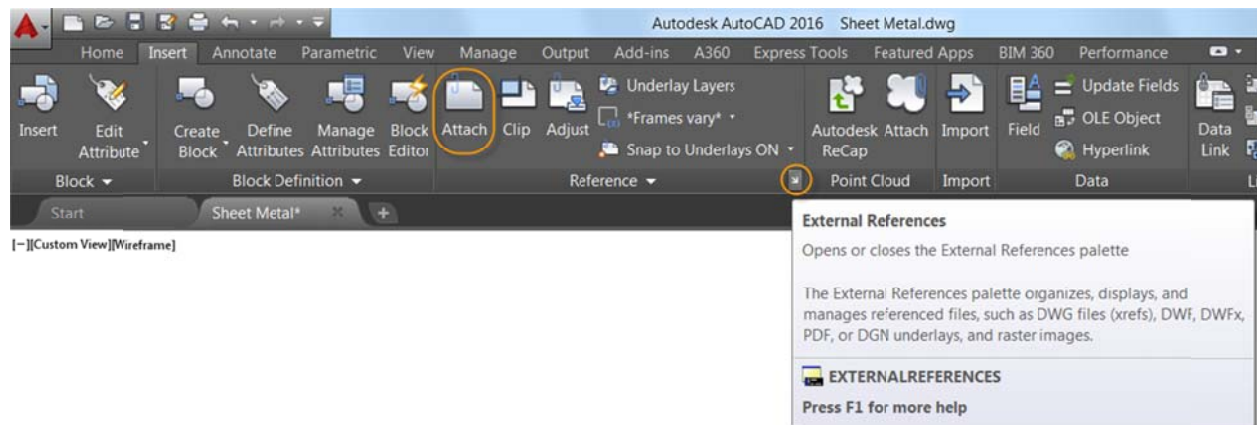

Navisworks files are listed among the other supported file types.

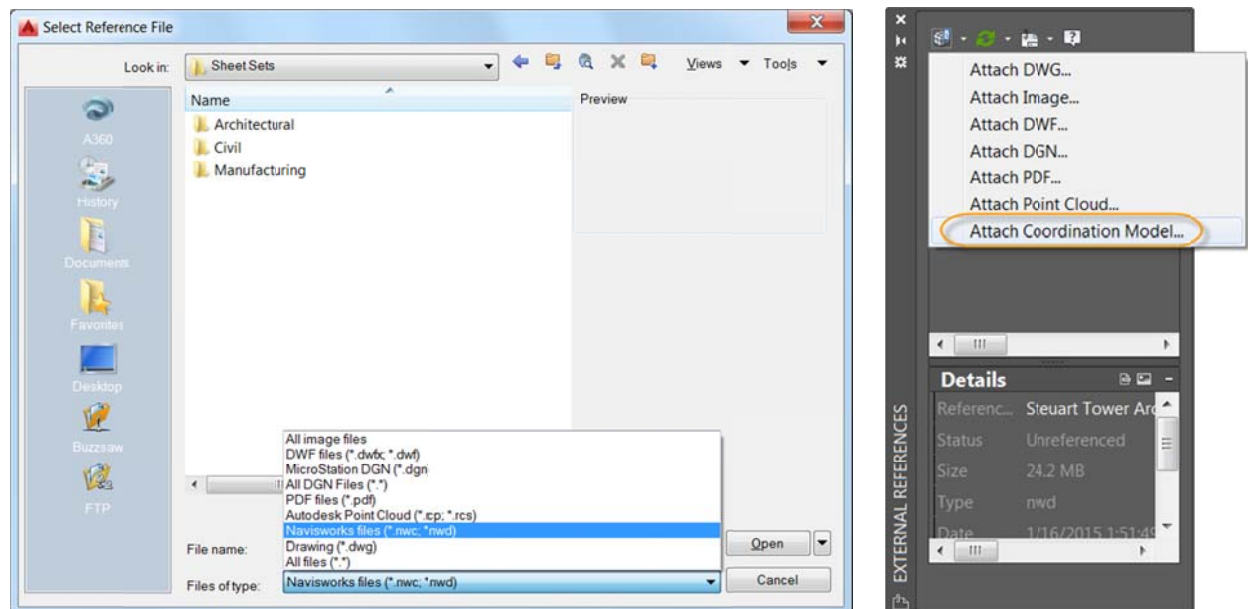

You can also attach Navisworks files using the new CMATTACH command (-CMATTACH for the command line version).

Regardless of which tool you use to attach a Navisworks file, the Attach Coordination Model dialog box is displayed. In here you can specify typical controls including Path type, Insertion point, Scale, and Rotation, as well as Display options that are specific to Navisworks files. If your drawing is part of the coordination model, you can hide that part of the model when it is attached. Just make sure Show current drawing geometry in model is not checked. That way your drawing geometry is not duplicated in the model. You can also automatically zoom to the coordination model within the drawing.

Controls on the Coordination Model contextual Ribbon tab make it easy to differentiate between the drawing geometry and attached coordination models. Color Fading controls the amount of black blended on all attached coordination models. Opacity Fading controls the amount of dimming through transparency for all attached coordination models.

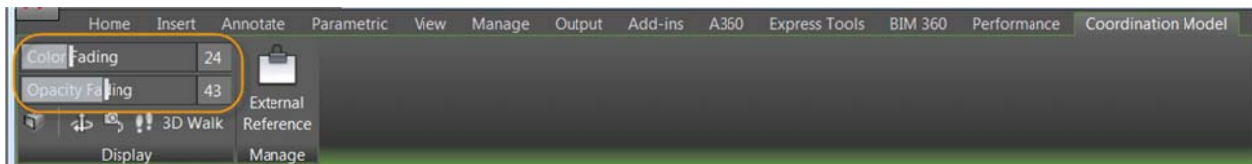

Color and opacity fading are set to 0 in the image on the left (below), making it difficult to differentiate the drawing geometry from the attached coordination model. In the image on the right, both controls are set to 50, making it easy to differentiate the drawing from the model.

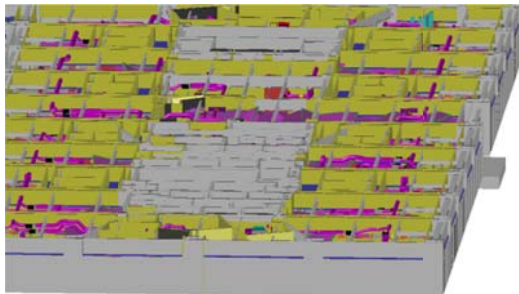

NOTE: Attaching a coordination model is not supported on 32-bit systems. To attach coordination models, you need a 64-bit system, and hardware acceleration must be turned on.

BIM 360 add-in for AutoCAD enhancements

The BIM 360™ add-in is enhanced so that you can attach single or merged models from BIM 360™ Glue® software to AutoCAD drawings. The new Attach tool is accessible from the BIM 360 Ribbon tab.

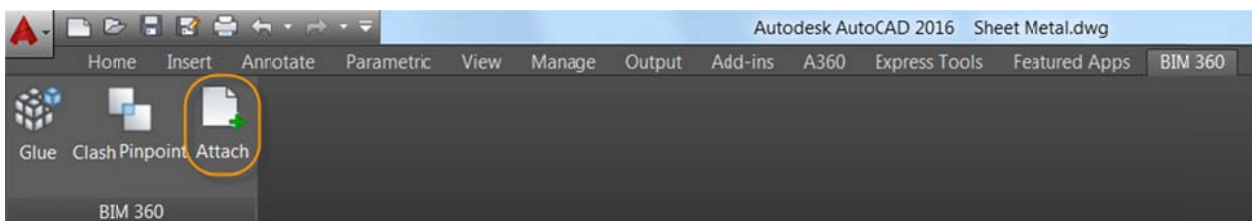

If you have a license for BIM 360 Glue, you can access your projects directly from AutoCAD by signing into your A360 account and selecting the project host. You can select which model or merged model you wish to attach and then specify its location within the current drawing.

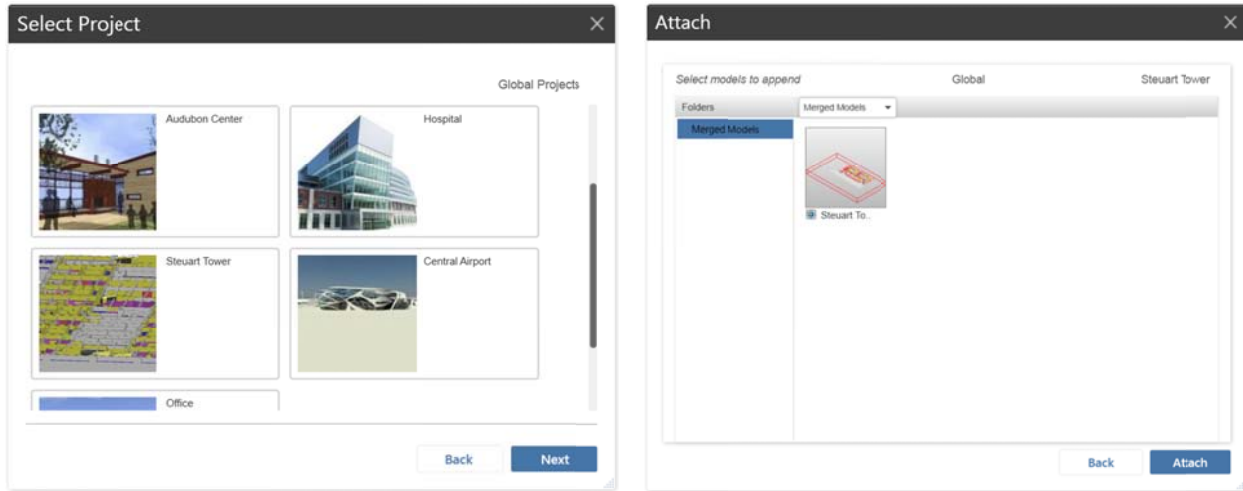

You can select the attached model to access the Coordination Model contextual Ribbon tab where you can adjust its color and opacity fading.

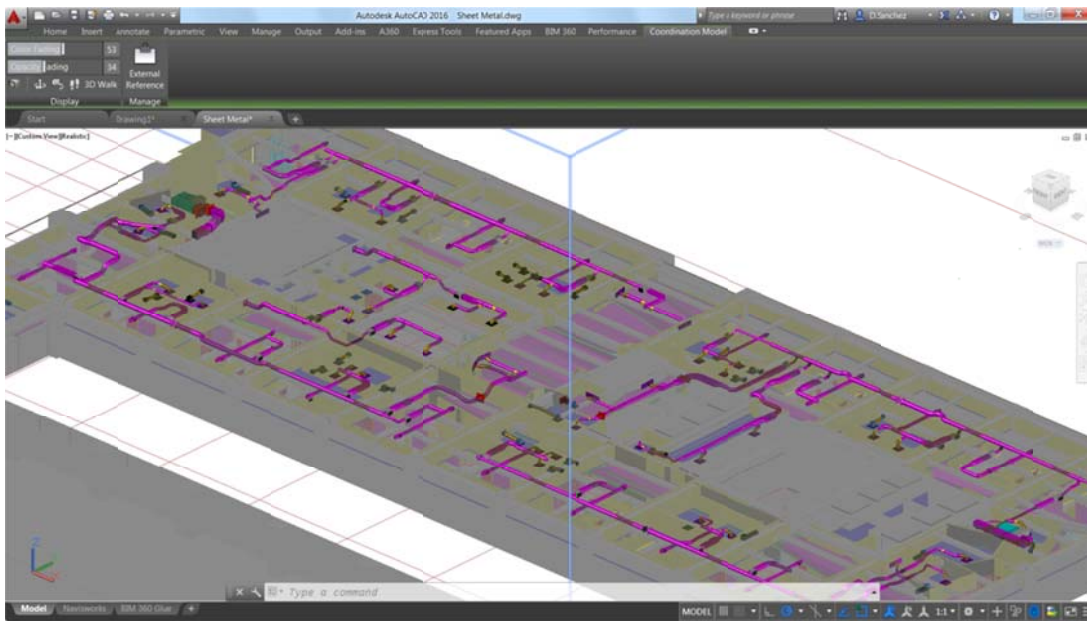

If a model from BIM 360 Glue is attached to a DWG™ drawing and the drawing is saved, when the drawing is re-opened, the latest version of the attached model is automatically loaded.

Installation and configuration

Improved graphics

The appearance of lineweights (for continuous linetypes) and curves (circles, arcs, ellipses, and elliptical arcs) has been enhanced in AutoCAD 2016. To see these improvements, your graphics hardware must be DirectX® 11-capable and you must have hardware acceleration turned on. A new control in the Graphics Performance dialog box enables you to take advantage of improved graphics for capable devices. You can access Graphic Performance from the Status bar icon.

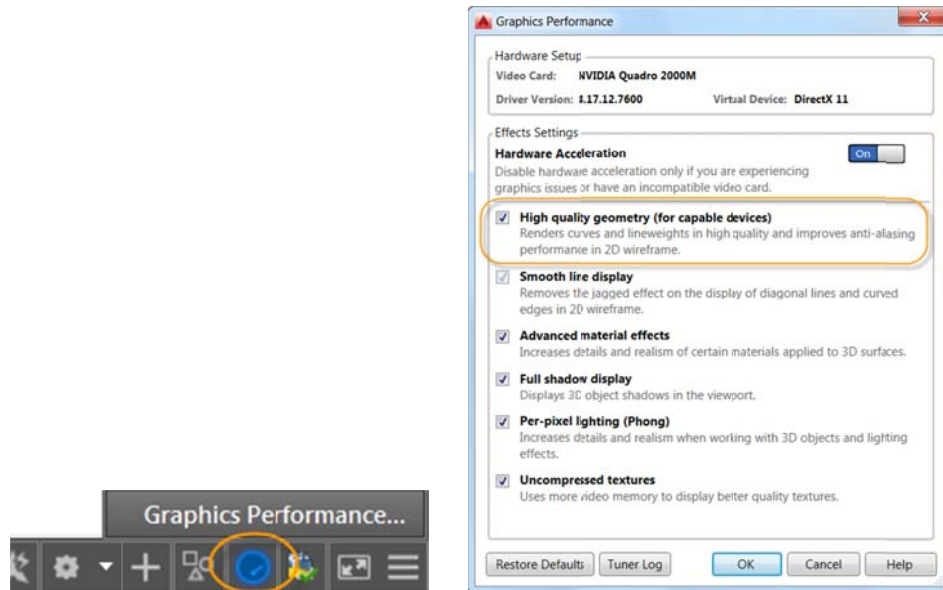

When enabled, you can display perfect curves in the 2D wireframe visual style and they will be smooth at any zoom level.

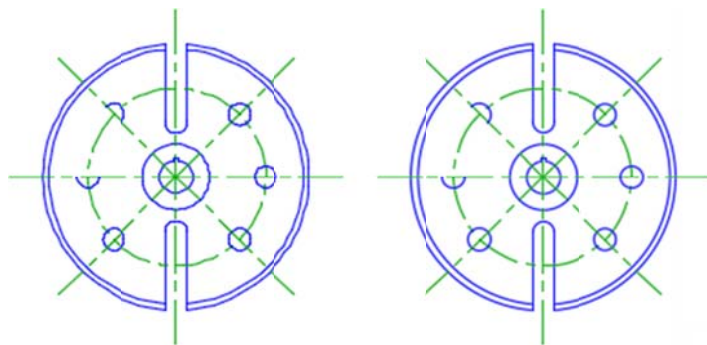

Two new variables offer additional control over the display when high-quality geometry is enabled. Turn `LINEFADING` on to automatically fade geometry as you zoom into dense drawings. The `LINEFADINGLEVEL` variable enables you to control the amount of fading between 1 and 3.

You are no longer required to perform a manual regen when zooming or panning as far as possible. The `REGENAUTO` system variable automatically performs the regens as needed.

A new CURSORBADGE system variable enables you to control the display of cursor badges. When it is set to 2, cursor badges are displayed. When it is set to 1, they are not.

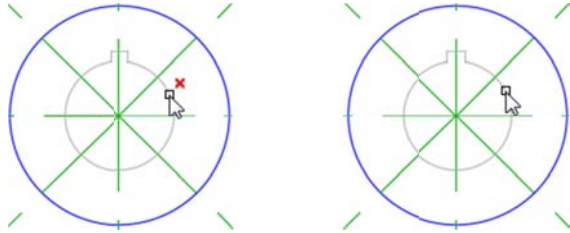

System Variable Monitor

The new System Variable Monitor (SYSVARMONITOR command) enables you to quickly identify and edit system variables that don't conform to your standards. The System Variable Monitor is prepopulated with a list of AutoCAD system variables that are often inadvertently modified. The status indicates which variables deviate from their default settings and the table displays the preferred and current values of those variables. You can click on values in the Preferred column and edit them to conform to your standards. You can use the Reset All tool to quickly reset the current values of all the deviant variables back to their preferred values.

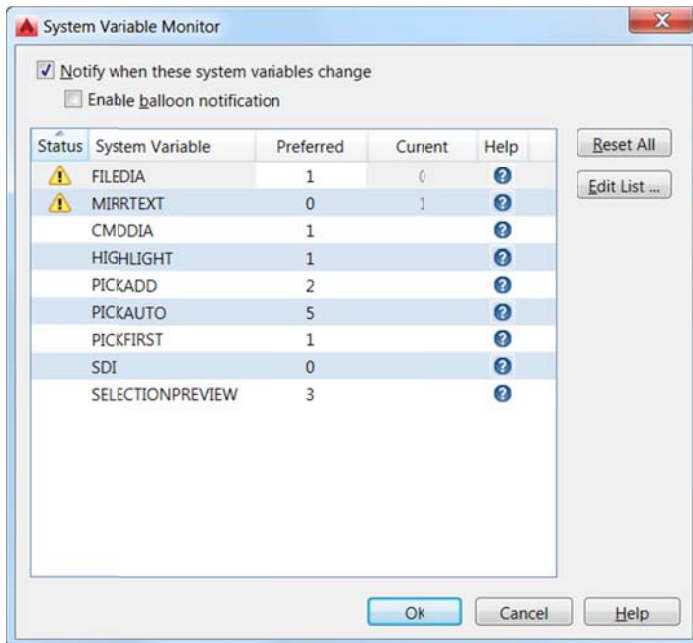

Easily add and remove variables by editing the list.

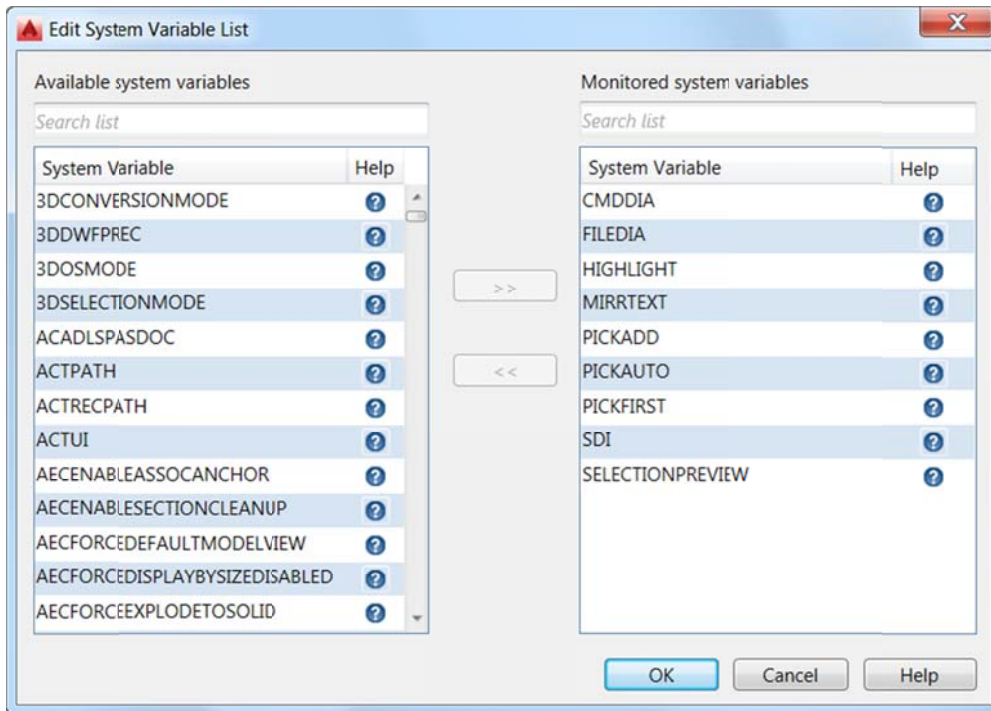

Controls in the System Variable Monitor (SYSMON system variable) enable you to display notifications when a system variable has changed from its preferred setting. If the control to Notify when these system variables change is turned off, you will receive no notification. If it is turned on, a notification will display at the command line and on the Status bar icon. If the additional option to Enable balloon notification is turned on, a balloon notification will display from the Status bar icon.

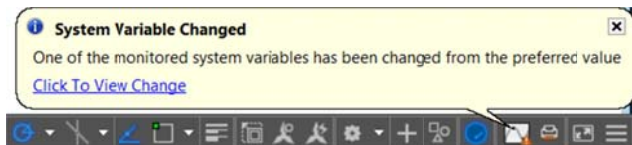

Security

In AutoCAD 2016 the Security controls on the Systems tab of the Options dialog box have been renamed from Executable File Settings to Security Options. The new Security Options dialog box offers a slider control to adjust the security level and you can browse, add, and remove trusted folders for executable files. Additional controls enable you to specify whether to include or exclude the Start In or drawing folders when searching for executable files. These controls are also accessible by the new LEGACYCODESEARCH system variable. You'll find similar security controls in the CAD Manager Control Utility and Deployment wizard.

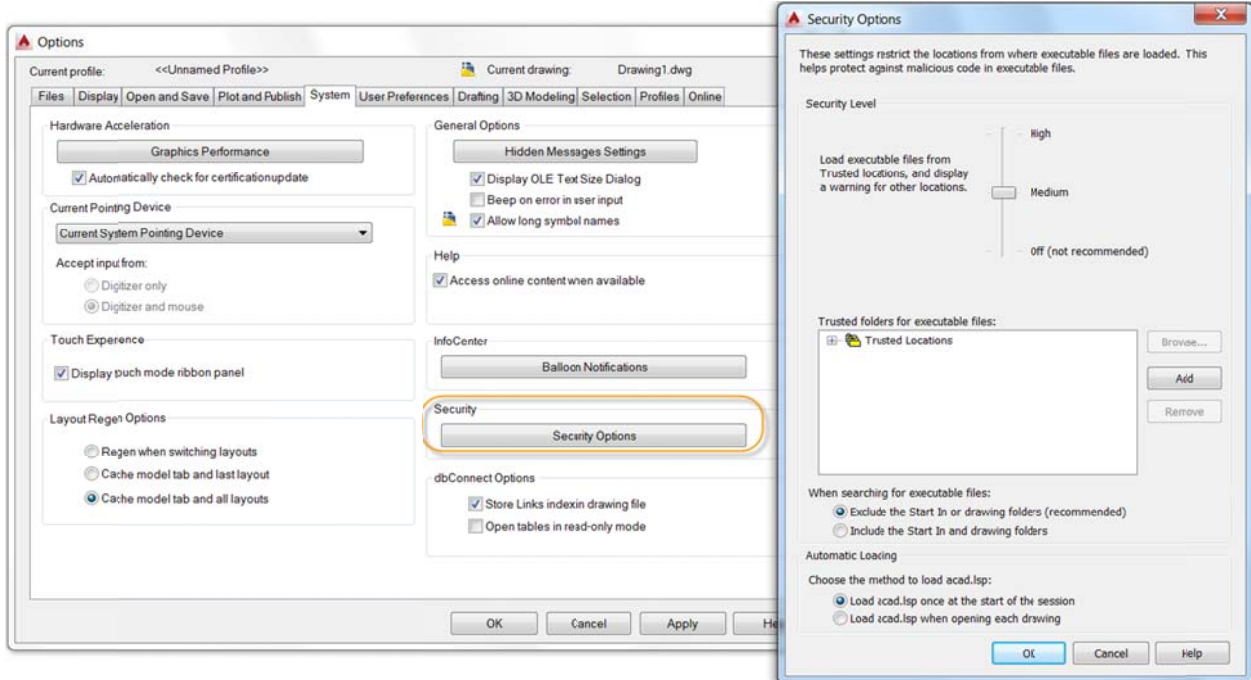

The Security Options dialog box is accessible via the command line using the SECURITYOPTIONS command. The digital signature controls that were previously located in the Security Options dialog box are now accessible via the new DIGITALSIGN command.

AutoCAD will warn if apps (including Exchange Apps) are loaded from program data or user data. It will not warn if unsigned apps are installed under program files.

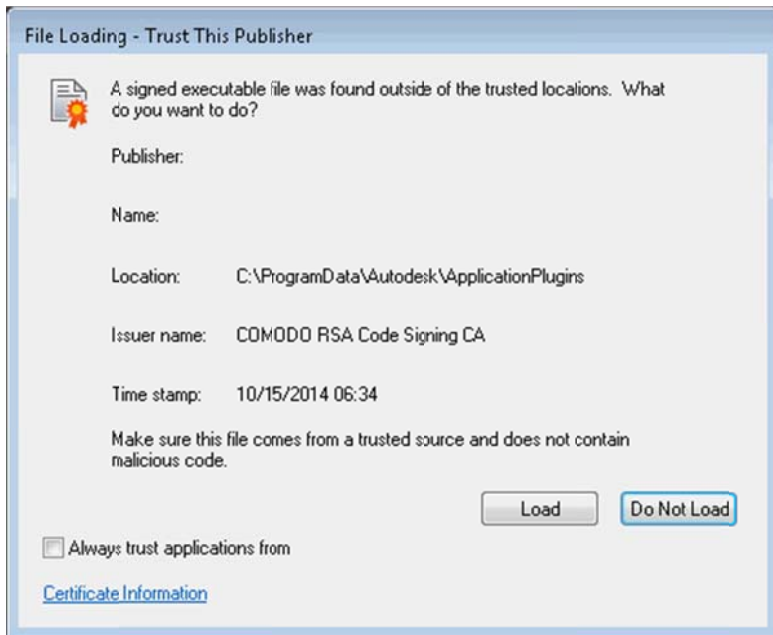

Single service pack

With the AutoCAD 2016 release, you can access your AutoCAD platform updates more quickly, even if you are using an AutoCAD-based vertical product. AutoCAD service packs created for AutoCAD 2016 can be installed on any AutoCAD 2016-based vertical product, so you don't have to wait for your vertical product to integrate the AutoCAD service pack changes. To help you identify which version you have installed, the About box is enhanced to provide information about the version level for both the AutoCAD platform and the AutoCAD verticals.

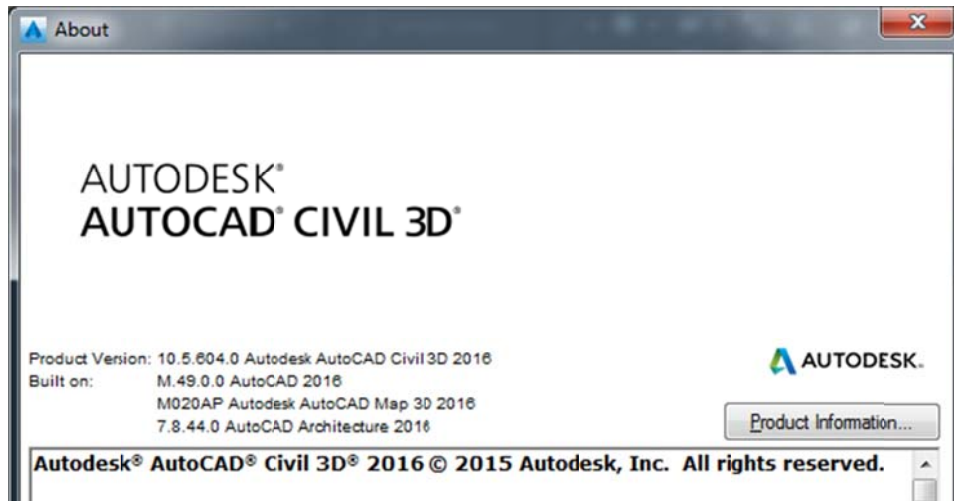

Autodesk, the Autodesk logo, AutoCAD, BIM 360, DWF, Glue, Navisworks, and TrustedDWG are registered trademarks or trademarks of Autodesk, Inc., and/or its subsidiaries and/or affiliates in the USA and/or other countries. All other brand names, product names, or trademarks belong to their respective holders. Autodesk reserves the right to alter product and services offerings, and specifications and pricing at any time without notice, and is not responsible for typographical or graphical errors that may appear in this document.

© 2015 Autodesk, Inc. All rights reserved.